

CAVIUS™

THE WORLDS
SMALLEST
SMOKE
ALARM



DANISH
DESIGN



5 YEAR
BATTERY

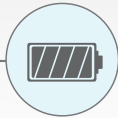

100%
TESTED

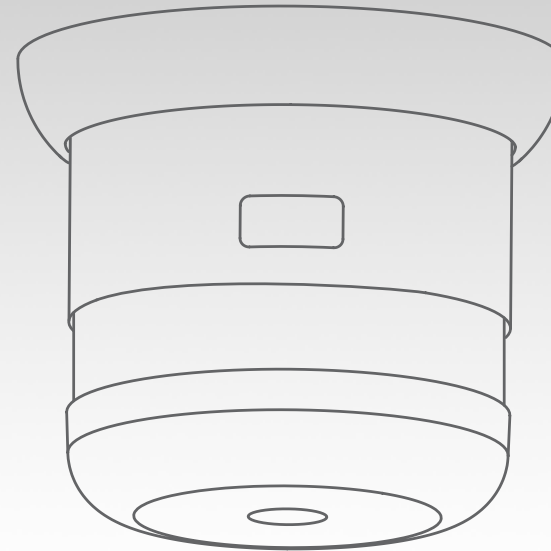

5 YEAR
SMOKE
ALARM

PRODUCT TYPE: OPTICAL SMOKE ALARM DEVICE

PRODUCT NUMBER: CAVIUS 2001-TK001



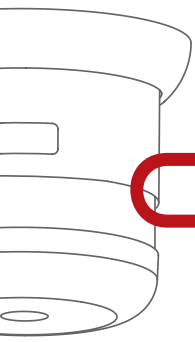

CAVIUS™

PRODUCT TYPE: OPTICAL SMOKE ALARM DEVICE

PRODUCT NUMBER: CAVIUS 2001-TK001

PRODUCT DATA:

SMOKE ALARM TYPE:

Optical Smoke Alarm device

USAGE:

Designed for installation in private homes, camping trailers, mobile homes and caravans. Not recommended for boats.

ISOTOPE ACTIVITY:

Absence of radioactive substances.

OPERATION AC/DC:

DC

BATTERY TYPE:

3V CR2 Lithium battery, 850mAh (replaceable).

POWER CONSUMPTION:

Battery consumption is 93mAhour in the non alarm condition.

BATTERY LIFE:

Minimum 5 year life in normal operating condition.
(Based on a weekly testing).

LOW BATTERY INDICATION:

A short acoustic “beep” will sound and LED flash every 48 seconds when the voltage is below 2.85V. In this stage it will continue for minimum 30 days, and can drive the alarm for 4 minutes.

NORMAL OPERATION:

LED flashes every 48 second for normal operation.

SOUND:

Audible indicator min. 85 dB @ 3 meter.

SOUND PATTERN:

Fire alarm condition is indicated by a series of three successive tones.

VISIBLE INDICATOR:

A red LED is used to indicate the following conditions:

- fire alarm condition is indicated by a flash every 0.5 seconds.
- smoke sense speed up is indicated by a flash every 2 seconds when the smoke level is at the alarm threshold.
- normal operation is indicated by a flash every 48 seconds.

PUSH BUTTON:

The smoke sensor includes a push button switch. This button has the following functions:

- hush – during an alarm condition this immediately silences the alarm when pressed. When the button is released, the alarm remains silenced for 10 minutes.
- test – when not in alarm the sounder can be activated to provide a sensor OK test function. While the button is pressed, the audible and visible indicators are activated if the sensor is OK.

WARRANTY:

1 year

PRODUCT WEIGHT (GR):

Base alarm weight (excluding battery screws, plugs and mounting ring): 31g

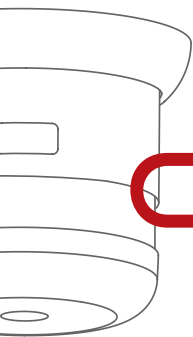

CAVIUS™

PRODUCT TYPE: OPTICAL SMOKE ALARM DEVICE

PRODUCT NUMBER: CAVIUS 2001-TK001

PRODUCT DATA:

OPERATING TEMPERATURE:

+4°C to +38°C (tested from 0 degrees to 55 degrees).

OPERATING HUMIDITY:

Up to 90% RH non-condensing

DETECTION TIMING:

The alarm makes an optical reading every 8 seconds. At unusual readings (going into alarm stage), the readings are taken every 2 seconds.

INSTALLATION POSITIONS:

Ceiling. Not recommended for wall use. Set of 2 x screws and 2 x plugs included.

APPROVALS:

EN 14604:2005
EN60065
NF292
ROHS
REACH

CE TESTING INSTITUTE:

CNPP

NOTIFIED BODY:

AFNOR Certification.

ADDITIONAL TESTING AND APPROVALS:

DVN (Dansk Varedeklarations Nævn).

NOTIFIED BODY NUMBER:

0333-CPR-2920051

AWARDS:

IF 2011 Design Award



product
design
award

2011 ■

STORAGE TEMPERATURE:

-20°C to +60°C

STORAGE HUMIDITY:

Up to 93% RH non-condensing

QUALITY ASSURANCE:

SOUND LEVEL:

100% tested in special designed sound chamber.

SENSITIVITY:

100% tested in special designed test tunnel made by world leader AWT (UK).

POWER CONSUMPTION:

100% tested

BATTERY VOLTAGE AND INTERNAL RESISTANCE:

100% tested

ALARM FUNCTION:

100% tested

VISUAL APPEARANCE:

100% tested

PACKING CONTENT:

100% tested

CONTACT

www.cavius.com

MANUFACTURER

Manufacturer: Cavius Aps, DK8600

CAVIUS™

THE WORLDS
SMALLEST
SMOKE
ALARM

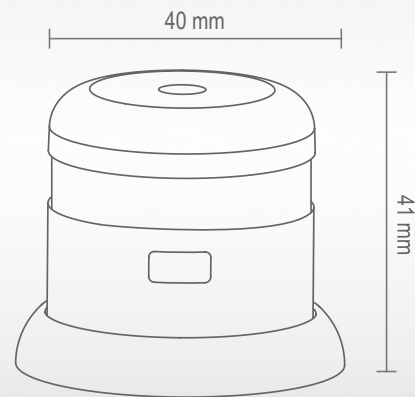

DISTRIBUTOR:

PRODUCT TYPE: OPTICAL SMOKE ALARM DEVICE

PRODUCT NUMBER: CAVIUS 2001-TK001